



BARCELONA

IMPACT AND NON-IMPACT WINDOWS



SoftLite
Windows & Doors



Beautiful Protection

Unparalleled impact protection. Cost-saving thermal efficiency. Exquisite beauty. Unmatched comfort. Intruder-resistant security. Long-lasting durability. Lifetime protection. When investing in your home, you want only the best. Barcelona windows can provide all of these benefits and truly transform your home.

Built with the finest materials that will look beautiful for decades, Barcelona windows are built with advanced manufacturing technology to ensure they will last.

Barcelona windows provide some of the best, most dependable storm protection available for your home. These windows effectively protect your home against debris from strong winds, storms, and other forms of violent weather year round. And, unlike shutters or boarded-up windows, these windows allow natural daylight in, making it easier and safer for you to function during power outages.

With Barcelona windows, you don't have to sacrifice beauty to achieve top-notch impact protection. Improve your home's curb appeal with a variety of styles, sizes, shapes, colors, or options. Possibilities abound, and whatever your dream for your home, Barcelona windows can help you achieve it!

SoftLite designed these windows to meet the needs of contemporary homeowners. Barcelona windows provide tremendous thermal performance to help reduce your home's energy costs. They provide outstanding protection against intrusion, making your home safer and more secure. In addition, these windows reduce damaging UV rays to keep your carpet and furnishings looking bright and new.

Standard Features Make Barcelona Windows Better

Barcelona windows far exceed all industry standards for energy efficiency, air and water penetration, and durability.



- Thick-walled vinyl frame with all corners fusion welded at high temperatures for strength. Frame has multiple internal chambers to provide optimal insulation.
- Stainless steel constant force balance system provides smooth, quiet operation on single-hung or double-hung windows.
- Easy-pull tilt latches on single- and double-hung models let you tilt in sashes to make cleaning a breeze.
- Insulating foam wrap around the frame reduces the likelihood of drafts between the window and any voids in your window opening.
- Marine (wet) glazing ensures a tight seal from the glass to vinyl frames. *Non-impact windows are tape glazed.*
- FlexScreen with a PVC-coated, high-performance spring steel frame that hides in pocket makes it virtually invisible and improves sightlines. *Casement BetterVue screens have an extruded aluminum frame.*
- Stainless steel spacer and sealant system flexes to reduce stress on the IGU seal. Provides excellent condensation resistance and thermal efficiency.



Cam-Action Lock

Heavy-duty, dual-direction 180° lock has impact keepers with two teeth held together by a slotted cam to withstand impact and cycling, secure sashes, and provide maximum weather protection.

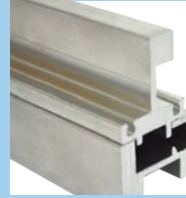

Metal Reinforcement

The sash rails feature special heavy-duty aluminum structural reinforcement for maximum strength, energy efficiency, and durability. Prevents the meeting rails from warping and improves the durability of the window to provide you with the best structural protection available during violent weather.



Vent Latches

Easy-to-operate vent latches allow fresh air in while preventing the sash from opening completely.

Barcelona Dura-Sill

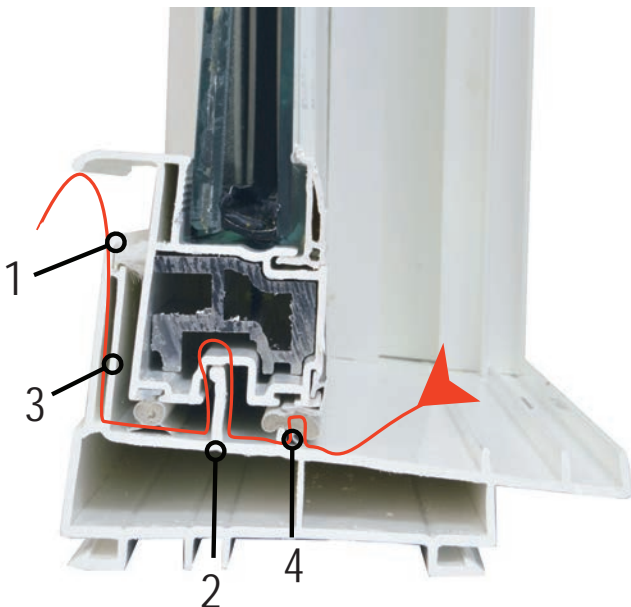

Pocket sill option available to meet coastal requirements.

- 1 Ultra-Smart™ weatherstripping:** Located on frame, sashes, and interlocking meeting rails and features Ultrafab® Triple-Fin® Gold Series gaskets with built-in Ultra-Fresh anti-microbial protection to minimize drafts, dust, and pollen. Improves insulation and window performance.
- 2 Structural interlock in bottom sash:** Our interlocking sill-sash rail keeps the sash in place against the sill dam weatherstripping when the window is under extreme wind-load stress.
- 3 Double-walled sill dam:** Tight, mortise-cut, double-walled sill dam extends inside the window mainframe jamb for uniform strength and seal.
- 4 Foam-Tite® compression seal with straddle gasket:** Gasket system straddles the sill rail when the sash is locked shut to add barriers and diversions for exceptional water resistance.

Quality Protection ... Luxurious Comfort

ENERGY SAVINGS AND COMFORT

When you think about creating a comfortable home, your windows should play a key role. Well-made, energy-efficient replacement windows are a must. You want windows that keep out cool drafts or summer heat and reduce the time your heating and air conditioning units run.

Barcelona windows are some of the best, most energy-efficient windows on the market and are ideal for saving energy dollars, safeguarding the environment, keeping you safe, and reducing your carbon footprint. These windows are packed with features that add up to offer truly exceptional energy efficiency.

SAFETY AND SECURITY

Barcelona impact windows help to safeguard your family and home against threats. Rugged frames, heavy-duty locks, and impact-resistant, laminated glass leads to enhanced security that will help fortify your home's vulnerable entry points and help defend against intruders.

Barcelona windows have passed the ASTM structural forced entry resistance testing, which determines the ability of a window to restrain, delay, or frustrate forced entry. This test is designed to measure a given amount of force applied to the product and its components in an attempt to gain entry.

STYLE AND SIMPLICITY

Another important consideration when buying windows is a fresh, clean, and beautiful appearance that you can admire — without spending hours on maintenance. Barcelona windows give you both.

From breeze-catching casements to gracefully designed double- or single-hungs, these stunning windows are also easy to maintain. Cleaning some windows can be exceptionally difficult, but Barcelona windows will save you time and aggravation because they allow you to access the outside of the glass for easy cleaning. And, our special-formula vinyl of the Barcelona window requires minimal maintenance.



SoftLite has been an ENERGY STAR® Partner of the Year since 2014 and has earned the Sustained Excellence award since 2016 for its outstanding contribution to reducing greenhouse gas emissions by manufacturing energy-efficient products and educating consumers about energy efficiency. Barcelona windows, coupled with high-performance glass, qualify for the ENERGY STAR label, helping you save money on your energy costs, while protecting the environment.



SoftLite, window sponsor with the National Crime Prevention Council, offers intruder-resistant windows.

The Best for Violent Weather

Barcelona impact windows are specially engineered to protect your home and loved ones from violent weather year-round and are available in two levels of protection.

Barcelona **Impact Level D** windows can be installed practically anywhere, even on the coastline. They pass the ASTM Large Missile Impact Level D tests, and have also achieved "HVHZ" certification, which means they are tested and approved for high-velocity hurricane zones. They carry a DP 50 rating or better in accordance with AAMA's 101 standard for air, water, and structural wind load testing.

Our **Impact Level C** windows are ideal for coastal and inland areas that are prone to violent weather and require windows that are tested for Missile Level C impact, these windows also carry a minimum DP 50 rating.

Barcelona impact windows undergo rigorous testing and easily passed:

- ASTM 1886/1996 Large Missile Impact tests
- ASTM E330 Wind Load Tests
- ASTM E331 Water Penetration Tests
- TAS 201, 202, and 203 Tests
- Validated and approved for the 2023 7th Edition of the Florida Building Code



Barcelona windows incorporate high-performance laminated glass – with two panes of glass and a protective interlayer. This unique glass is so strong it can withstand repeated blows by hammers, crowbars, and baseball bats before it can be penetrated. Even when shattered, the glass is virtually impenetrable. This makes the Barcelona an excellent barrier against airborne debris and other dangers from violent weather.

FLORIDA WIND SPEED MAP

Wind-borne Debris Region

- Designated areas where the basic wind speed is ≥ 140 mph
- 130 mph and within 1 mile of coast

Notes:

1. Values are ultimate design 3-second gust wind speeds in miles per hour (m/s) at 33 ft (10,) above ground for Exposure C category.
2. Linear interpolation between contours is permitted.
3. Islands and coastal areas outside the last contour use the last wind speed contour of the coastal area.
4. Mountainous terrain, gorges, ocean promontories, and special wind regions shall be examined for unusual wind conditions.
5. Wind speeds correspond to approximately a 7% probability of exceedance in 50 years (annual exceedance probability = 0.00143, MRI = 700 years).
6. This map is accurate to the county. Local governments establish specific wind speed/wind-borne debris lines using physical landmarks, such as major roads, canals, rivers, and shorelines.

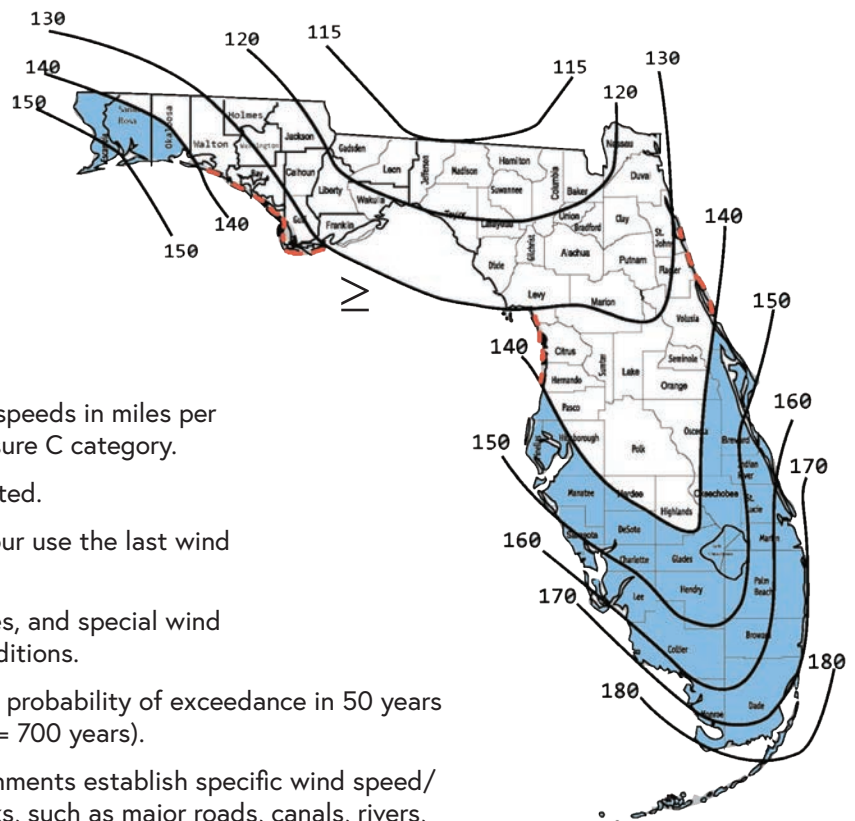

Best Performance Against Violent Weather

High-performance, impact-rated glass for storm protection, comfort, efficiency, sound reduction, and more. Barcelona windows are available with three levels of impact protection — Level C, Level D, and HVHZ — to meet the building codes in your area. All Barcelona windows have undergone thorough air, water, and structural testing and are ENERGY STAR® certified and provide the best thermal performance for your climate region, which will save you money on your home energy bills and significantly enhance the comfort of your home.

BARCELONA LEVEL D/ LARGE MISSILE IMPACT-RATED WINDOWS

Provide protection against both storm debris and intrusion. They can be installed right on the coastline and some models have HVHZ certification, which means they are approved for High Velocity Hurricane Zones. These windows incorporate a high-performance glass system featuring:

- A tough layer of 0.90" laminated glass that is comprised of a polyvinyl butyral interlayer between two panes of glass and bonded together with intense heat and pressure to provide a clear, high-strength protective layer of glass.
- Deeply embedded glass that is glazed into the frame, offering optimum structural integrity and amazing impact protection because it's virtually impenetrable.
- A highly advanced Low-E coating is applied to the glass to help reduce home energy costs and provide enhanced UV protection for your carpet, artwork, and furnishings.
- Safe argon gas between the panes to improve the insulation properties of the glass and lowers home energy costs.
- Stainless steel spacer system is time-proven for long-term seal dependability and reduces energy loss for optimal thermal performance.

High Velocity Hurricane Zone Windows. HVHZ areas are located in Miami-Dade and Broward counties. These windows undergo additional water and structural testing along with additional missile impacts to simulate violent storms and hurricane conditions.

SentryGlas® laminate is available for larger units that require more protection — up to five times the tear strength and 100 times the rigidity of other PVB interlayers.

BARCELONA IMPACT LEVEL C WINDOWS

Impact Level C windows also offer many of the same benefits as Level D windows. They're ideal for areas that are prone to violent weather conditions. They also feature deeply embedded glass, Low-E coating, argon gas, and a stainless steel spacer system like the Level D windows. The Level C high-performance glass system is a tough 0.60" laminated polyvinyl butyral interlayer that is just slightly thinner than our Level D windows but still provides tremendous impact protection.

NAMI Gold Level D/Large Missile Level Label



NAMI Gold Level HVHZ Label



NAMI Gold Level C Label

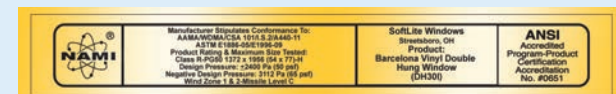

Optimum Air Infiltration

INDUSTRY STANDARD

.30 CFM

of air leakage per minute



2.25 gallons of air per minute

Traditional Wood Residential Double-hung windows

.23 CFM

of air leakage per minute



1.725 gallons of air per minute

Traditional Vinyl Residential High-Performance Double-hung windows

.15 CFM

of air leakage per minute



1.125 gallons of air per minute



BARCELONA

.01 CFM

of air leakage per minute



0.075 gallons of air per minute

Barcelona windows are up to 30 times more airtight than the industry standard and 15 times more airtight than most vinyl high-performance windows on the market today.



NAMI GOLD LABEL FOR STRUCTURAL INTEGRITY

The National Accreditation & Management Institute is nationally recognized accrediting source for the structural design performance of windows and doors. NAMI's Structural Certification Program is accredited by the American National Standards Institute (ANSI) and the International Accreditation Service (IAS). The program is also recognized by the state of Florida. If you demand windows and doors that meet stringent performance standards, just look for the NAMI certification label. Products that have earned the right to display this label have passed independent laboratory tests to ensure they comply with the applicable test standards.

WHY DO WINDOWS LEAK?

Poorly designed windows don't have the built-in airlocks, weatherstripping, and barriers necessary to prevent air infiltration. Without these design features, air will push between the sash meeting rails and around the sash perimeter where it meets the frame and sashes.

We know how uncomfortable a home with leaky windows can be. So, we loaded the Barcelona window with weather barriers that go far beyond the industry standard and other manufacturer's window designs.

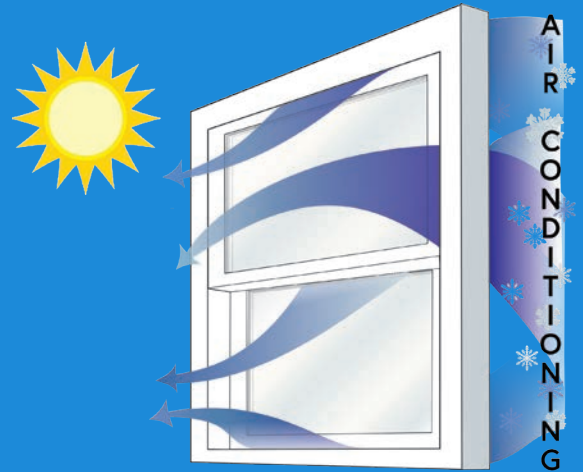

THE LOWER THE CFM RATING ...

- The less inside air will leak outside
- The more comfortable your home will be with fewer drafts
- The less your furnace or air conditioner will run and the more money you'll SAVE
- The smaller your carbon footprint

LEVEL D DOUBLE-HUNG
+55 -65 | AIR: 0.01

LEVEL C DOUBLE-HUNG
+50 -65 | AIR: 0.01

LEVEL D AND C SINGLE SLIDER
+55 -60 | AIR 0.02

LEVEL D SINGLE-HUNG
+60 -65 | AIR: 0.01

LEVEL C SINGLE-HUNG
+55 -65 | AIR: 0.01

Single- and Double-Hung

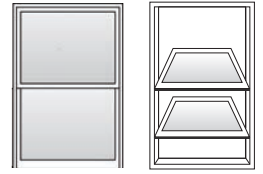

Exterior view

Single-hung windows, which incorporate one top fixed lite and one bottom sash that slides up and down, are a beautiful, practical choice for many coastal homes. Barcelona single-hung windows are ideal for homeowners who prefer this operating style, because they will enhance the beauty of any home — yet are built to provide decades of impact protection, thermal efficiency, security, durability, and easy operation, like all SoftLite products.

Barcelona single-hung windows offer you a wide array of features, benefits, and options. They are available as impact or non-impact windows and boast heavy-duty frames as do our double-hung windows. They include a tilt-in bottom sash for easy cleaning. They can be designed using the geometric shape of your choice to give your home a more one-of-a-kind look and feel.

Single-hung windows and single-hung archtop windows meet coastal window opening needs.



Barcelona **double-hung** windows are some of the best, most secure and energy-efficient windows on the market — ideal for impact protection, saving energy dollars, safeguarding the environment and reducing your carbon footprint. Multi-chambered, foam-filled frames made of the very best vinyl, custom crafted with welded sash and frames that boast very tight tolerances, and the most advanced glass technology all adds up to a window that offers truly superlative impact protection, energy efficiency, and so much more.

Barcelona windows stand apart from all the rest as the ultimate window for your home. In addition to their unbeatable impact protection and excellent energy-efficient properties, they offer countless other benefits, such as intruder-resistant security, long-lasting durability, stunning beauty, and minimal maintenance.

Barcelona windows can be designed to reflect your personal tastes and preferences. Modern and contemporary. Classic and traditional. Elegant and luxurious. Stunningly original. Impact or non-impact. No matter what style you prefer, Barcelona windows can help you achieve it for your home. Get precisely the look you want with a wide assortment of options, including various exterior colors, between-the-glass grids, or specialty shapes.

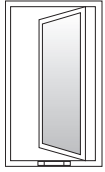

Interior view

The Barcelona **casement** window is the epitome of perfect form and function in a specialty window. Designed with the clean lines of a picture window, it offers added ventilation and the freedom of opening the sash to the outdoors. At the same time, casement windows create a strong seal that offers excellent thermal efficiency and enhanced comfort in your home.

Barcelona casements open with just the turn of a handle. Available as left- or right-hinged windows, they open to the outside, providing refreshing ventilation. The easy-to-use, durable, crank handle and hardware* ensure that you will be able to open and close your windows with ease for years to come.

These windows are also designed with a single-lever lock handle that easily engages and locks multiple lock points within the window's mainframe when closed, making your home more secure and resistant to intrusion.

- *Impact casements available as single units only*
- *Impact mullions available*
- *Egress hardware available*
- *Non-impact windows also available*

**Coastal applications require stainless steel hardware*



Casement screens feature invisible retention hardware, eliminating screen clips. The extruded screens have BetterVue HD fiberglass screens that provide enhanced viewing, airflow, and insect control.



Hidden stainless steel, multi-point locking rollers engage with stainless steel keepers on the sash.



A single lock lever activates multi-point lock bar on the frame and engages with the keepers on the sash.



Robust strength in a low-profile, standard fold-down handle design. The easy-to-open-and-close handle and hardware last a lifetime.

Sliders

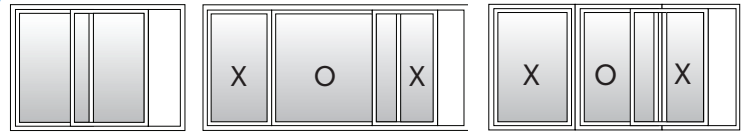

2-lite slider
XO or OX for impact
XX for non-impact

3-lite slider 1/4-1/2-1/4
configuration (standard)

3-lite slider 1/3-1/3-1/3
configuration (optional)

"O" = fixed lites. "X" = operating lites. All views interior.

Think of the **sliding window** as a double-hung turned on its side! It combines all the features of a double-hung (without the need for balances). Barcelona sliding windows are beautifully designed to provide an unobstructed view, yet built tough for decades of weather protection and smooth operation. They too, are available as impact or non-impact windows.

Sliding windows are an ideal style if you're looking for a wider window that offers a more panoramic view of the outdoors. You can choose from different window configurations, so you get precisely the look and feel you want to achieve for your home.

All Barcelona sliding windows roll easily and dependably on corrosion-resistant brass rollers. For ease of cleaning, the operating sashes easily lift out.

If you want to create a room with a spectacular view — a vast window to the outdoors — Barcelona sliding windows may be the perfect choice for your home.



Durable brass sash rollers ensure easy operation of our slider windows



Secure locking hardware provides superior safety and security



For unmatched quality, performance, and ease of installation, Barcelona also offers the **DP65 slider**. This window offers all the benefits of the Barcelona window, but with removable sashes for easier installation, increased testing performance, and a higher DP rating!

The Barcelona DP65 impact slider stands out above the competition as it can be installed from the interior of the building ... even the fixed sash can be removed for easier handling while installing or for future warranty service.

Available as XO or OX only.



Strong Metal Reinforcement - Stainless steel L brackets at keeper rail connect to the L channel in the mainframe head and sill as well as the external keeper rail reinforcement for extra durability and protection during violent weather.

High-Performance Glass Options

SoftLite offers an array of advanced insulating glass systems that can be tailored to best perform in your climate region. This ensures that your new Barcelona windows will provide the best possible performance for your home, which will save on energy costs. All Barcelona windows feature double-strength glass for added durability (heavy-duty glass and triple-pane glass are also available). Here are some samples of the glass packages and ratings for both impact and non-impact glass.

Solar Low-E Glass (non-impact)

Double-hung, one high-performance Low-E coating, one Low-E coating, double-pane, double-strength glass, stainless steel spacer, and argon gas.

U	S	V	C
0.31	0.19	0.45	58

Meets
ENERGY STAR®
7.0
in Southern zone

Ultra Low-E Glass (non-impact)

Double-hung, one high-performance Low-E coating, one Low-E coating, triple-pane, double-strength glass, stainless steel spacer, and argon gas.

U	S	V	C
0.28	0.22	0.38	59

Meets
ENERGY STAR®
7.0
in South-Central and Southern zones

Armor Glass Plus Solar Low-E (non-impact/non-impact)

Double-hung, two high-performance Low-E coatings, .060 laminate, double-pane, heavy-duty glass, stainless steel spacer, and argon gas.

U	S	V	C
0.31	0.19	0.44	58

Meets
ENERGY STAR®
7.0
in Southern zone

Armor Max Plus (impact)

Double-hung, Low-E coating, .090 laminate, double-pane, heavy-duty glass, stainless steel spacer, and argon gas.

U	S	V	C
0.31	0.19	0.44	58

Meets
ENERGY STAR®
7.0
in Southern zone

U = U-Factor S = Solar Heat Gain Coefficient
V = Visible Transmittance C = Condensation Resistance

Obscure Glass

Non-laminated obscure glass distorts view to provide privacy while allowing light through the window. Laminated obscure glass contains a white interlayer that you cannot see through.

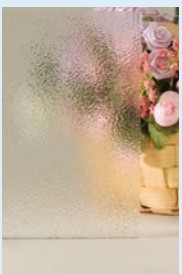

NON-LAMINATED

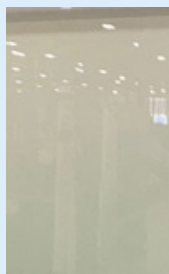

LAMINATED

Armor Glass® is a security glass that helps to protect your windows from break-ins, hurricane winds, and solar heat.

Double-strength glass is 3.2 mm thick instead of the single-strength 2.5 mm. **Heavy-duty glass** is 5.0 mm thick.

Low-E glass has a thin coating to minimize infrared and UV rays without lessening the light that enters your home. This helps keep the temperature in your home consistent by reflecting the interior temperatures back inside.

Tempered glass (safety glass) is four times stronger than standard glass. If it breaks, it shatters into tiny pieces that are much less likely to cause an injury than the large, sharp shards.

SentryGlas® laminate is five times the tear strength and 100 times the rigidity of a conventional PVB interlayer

Turtle glass is available to meet coastal requirements as it does not reflect exterior light, so turtles will not be drawn toward your home.

Options to Customize Your Windows

You don't have to forego beauty for strength. Our selection of different colors, grids, and shapes gives your home an entirely new look. Internal grids give your windows the look and feel of divided-lite windows but allow for easy cleaning. Internal grids are available in both a contoured or flat design in regular and wide widths and in several distinctive patterns. *Pencil grids also available. Check with your dealer to see which grid choices work with specific patterns.*

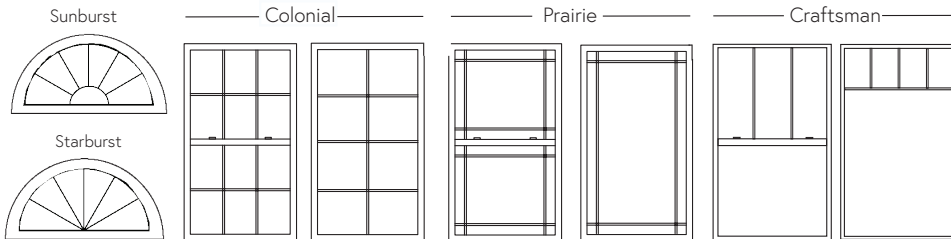

This is just a sampling, several grid patterns are available. Grid pattern availability and appearance is based on window size and shape.

DECORATIVE GRIDS

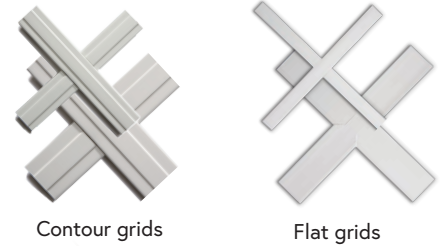

Grids available in all colors

Simulated Divided Lites (SDLs) maintain the historic beauty of your home, and achieve the look of true colonial-style windows, with grids applied to both the interior and exterior panes. *Not available on triple-pane windows*

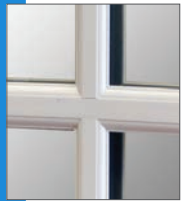

VINYL COLOR

INTERIOR/EXTERIOR



SOFT-WHITE

SURE-COAT PVC STANDARD BOND COLORS

EXTERIOR

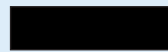

BLACK 09

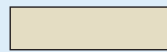

ALMOND 20

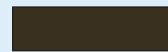

BRONZE 21

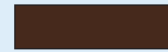

ROYAL BROWN 24



TERRATONE 53

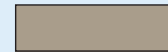

SIERRA 83

Sure-Coat colors are warranted for 10 years. Custom colors are available for a fee.

SHAPES

For special openings and accents, customize the shape of your windows to your specifications. All shapes are fixed-lite (non-operable) units. This is a sampling of the shape types.

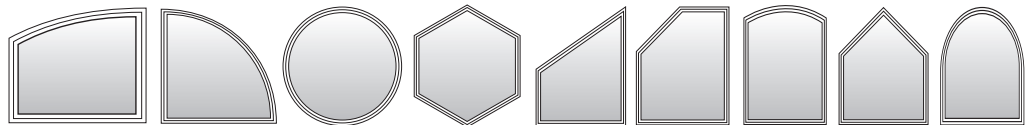

LIMITED LIFETIME WARRANTY



Our Limited Lifetime Warranty is designed to protect your investment and our reputation. It guarantees that our windows will not rot, rust, warp, pit, corrode or blister, and that our vinyl colors will remain true for the life of your home. Our Limited Lifetime Warranty is non-prorated, fully transferable, and covers all moving parts and the hermetically insulated seal against defects in materials or workmanship. We also offer the ultimate in protection with an optional, non-transferable lifetime glass breakage rider for extra peace of mind for non-impact windows. Go to www.soft-lite.com/lifetime-warranty to view our warranty, specific terms, and conditions.

CONNECT WITH US!



BARCELONA

www.soft-lite.com